

681427 3 SPOOL PLUMBING KIT FOR CASE 1896-2090-2094-2096-2290-2294

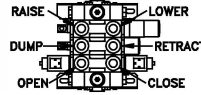

SHORT LINE PARTS, LLC
SALES@SHORTLINEPARTS.COM

TOP VIEW OF WORKING PORTS ON THE VALVE



USE THIS JOYSTICK BRACKET IF CONSOLE IS AHEAD OF FENDER

NOTE: AFTERMARKET PBY REPLACED WITH OEM PBY. LOAD SENSE HOSE CONNECTS DIRECTLY TO OEM PBY, AND SHUTTLE TEE IS NOT USED.

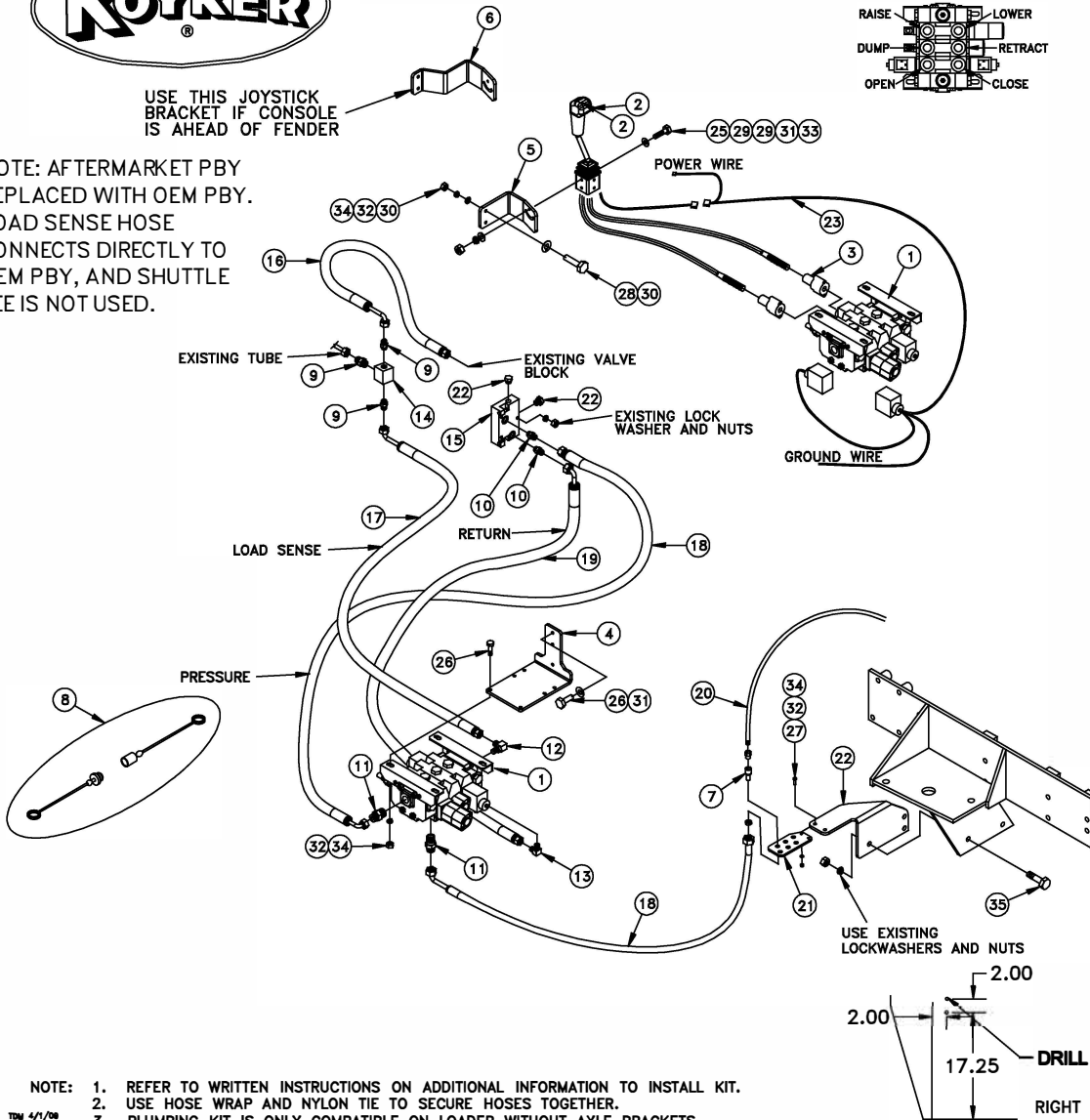

KEY	PART NO.	DESCRIPTION	QTY.
1	668963	3 SPOOL VALVE (LOAD SENSE)	1
2	683155	JOYSTICK CABLE CONTROL KIT W/78" CABLES	1
3	669298	CABLE CONNECTOR KIT	2
4	678738	VALVE PLATE	1
5	684724	JOYSTICK HANDLE BRACKET	1
6	680369	JOYSTICK HANDLE BRACKET	1
7	673740	QUICK COUPLER SET	6
8	673957	COLOR COUPLER PLUG KIT	1
9	659837	ADAPTER: 6MJX-6ORM	3
10	675515	ADAPTER: 8MJX-8ORM	2
11	659838	ADAPTER; 8MJX-10ORM	7
12	679501	90° ELBOW; 6MJX-10ORM	1
13	675513	90° ELBOW; 8MJX-10ORM	1
14	674073	VALVE - SHUTTLE TEE	1
15	678743	BLOCK - CASE	1
16	678794	16" HYDRAULIC HOSE (SHUTTLE TO TRACTOR)	1
17	673908	48" HYDRAULIC HOSE (LOAD SENSE)	1
18	675512	48" HYDRAULIC HOSE (RETURN & WORK)	7
19	676981	60" HYDRAULIC HOSE (PRESSURE)	1
20	673909	72" HYDRAULIC HOSE (COUPLE TO LOADER)	6
21	672858	COUPLER PLATE	1
22	681423	MID COUPLER PLATE	1
23	683162	WIRING HARNESS	1
24	660669	ADAPTER; PLUG 8ORM	2
	669686	36" HOSE WRAP	2
	652393	NYLON TIE	5
	#376	HARDWARE BAG	1
25	669618	HH CAP SCREW; 5/16" x 3 1/2"	2
26	640028	HH CAP SCREW; 3/8" x 1"	6
27	640034	HH CAP SCREW; 3/8" x 1 1/4"	3
28	640037	HH CAP SCREW; 3/8" x 2"	2
29	640152	FLATWASHER; 5/16"	4
30	640154	FLATWASHER; 3/8"	2
31	640151	LOCKWASHER; 5/16"	2
32	640153	LOCKWASHER; 3/8"	7
33	652360	HEXNUT; 5/16"	2
34	640132	HEXNUT; 3/8"	7
35	651220	HH CAP SCREW; 3/8" x 2"	2
	663708	JOYSTICK DECAL	1

NOTE: 1. REFER TO WRITTEN INSTRUCTIONS ON ADDITIONAL INFORMATION TO INSTALL KIT.
2. USE HOSE WRAP AND NYLON TIE TO SECURE HOSES TOGETHER.
3. PLUMBING KIT IS ONLY COMPATIBLE ON LOADER WITHOUT AXLE BRACKETS.

INSTALL FITTINGS
6400-8-12



3 SPOOL PLUMBING KIT #681427

Case 1896-2090-2094-2096-2290-2294

INSTALLATION INSTRUCTIONS:

1. The mount kit should be installed before proceeding to ensure that there is no interference.
2. Attach the new end block (Part #15) with two plugs (Part #24) to the valve on the left side under the cab. Use the existing nuts and lock washers. **See in Fig. 1-1.**
3. Install nine adapters (Part #11, 12 & 13) into the pressure, return, load sense and all the working ports on the top of the valve. Note: Attach all fasteners loosely to allow for desired adjustment later.
4. Install the valve (Part #1) onto the valve plate (Part #4) with four 3/8" x 1 1/4" HH cap screws, lock washers and hex nuts (Part #26, 33 & 35).
5. Attach the valve plate (Part #4) onto the RH side behind battery. Secure with two 3/8" x 1" HH cap screws, lock washers and nuts (Part #26 & 31). **See in Fig. 1-2.**
6. Drill two holes in the right fender to install the handle bracket (Part #5 or 6). Using two 3/8" x 2" HH cap screws, flatwashers, lock washers, and nuts (Part #28, 31, 33 & 35) attach the bracket that best fit the tractor.
7. Install the joystick (Part #2) with two 5/16" x 3 1/2" HH cap screws, lock washers, hex nuts and flat washers (Part #25, 30, 32 & 34), if joystick needs a 1/4 turn remove two sleeves for the bolts from joystick and reinsert them at a 1/4 turn. Note: Attach all fasteners loosely to allow for desired adjustment later.
8. Attach the cable ends to the valve body with the connector kits (Part #3). **Note: Make sure the joystick is in the locked position.** (Center the joystick and push the joystick knob in (located on the side of joystick) to lock joystick.) First screw the nut on to the cable then put the small o-ring on the cable past the threads. Slide large o-ring on the connector and thread the cable connector and slide the valve controller on the cable. Now thread the small nut and the pin connector onto the cable and tighten. Make sure the end of the cable does not hit the valve push rod. Now push pin connector onto the valve push rod and slide the pin through the holes. Thread the cable connector to the valve by hand. **Note: Only hand tighten the**

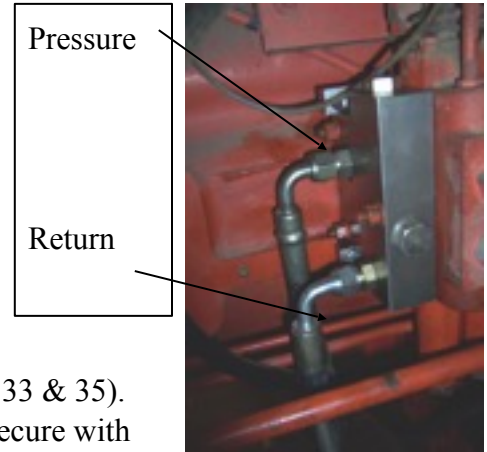

Fig 1-1



Fig 1-2



Fig 1-3

valve connector, if over tighten the joystick will not be right. Now push large o-ring to the valve into the groove of cable connector. Then slide the valve connector to the valve and bolt together with given Allen head bolts. Slide the small o-ring to cable connector groove on the end and thread the large nut to cable connector and tighten. **Note: Make sure the cable connector does not move. See in Fig. 1-3 and 1-4.**

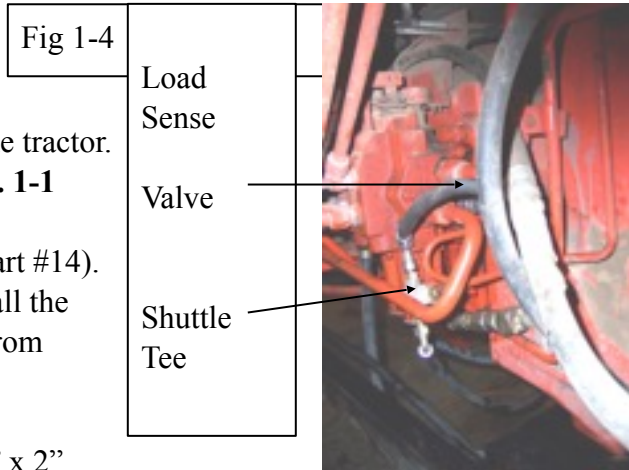

Fig 1-5

9. Next attach the wiring harness (Part #22) onto the valve; the electrical should be under the right side of cab. You will have to disconnect the electrical ends of the wiring harness, and then cut the ends off of the tractor harness. Now connect the wire the ends and connect to the valve. Note: The wire from tractor has power and ground.
10. Route the 48" and 60" hoses (Part #13 & 14) underneath the tractor cab and attach to the proper ports on the manifold block already installed on the back of the tractor. See instruction sheet for proper connections. **See in Fig. 1-1 and Fig 1-2.**
11. Install the three adapters (Part #9) into the shuttle tee (Part #14). Disconnect the load sense line for the tractor valve. Install the shuttle to load sense tube. Run the 16" hose (Part #16) from shuttle tee to tractor valve. **See in Fig. 1-5.**
12. Route the 48" hose (Part #17) from valve to shuttle tee.
13. Install the mid coupler bracket (Part #22) using two 5/8" x 2" HH cap screws (Part #34) with the existing lock washers and hex nuts.
14. Next put the bulk head adapters and the male half (Part #7) on the mid-mount couple plate (Part #21). Note: At this point install the female half of the colored plugs (Part #8) along with the couplers.
15. Now install the mid-mount couple plate (Part #2) with two 3/8" x 1 1/4" HH cap screws, lock washers and hex nuts (Part #27, 33 & 35). **See in Fig. 1-6.**
16. Run hydraulic 48" hoses (Part #18) from valve to mid-mount coupler.
17. After this has been done attach the female half of the quick coupler (Part #7) onto the 72" hoses (Part #20). Note: At this point install the male half of the colored plugs (Part #8). Attach the other end of the hoses to the steel oil lines on the loader frame. Then attach to the mid-mount coupler. Refer to the top view of the working port diagram and the loader manual to determine the function of the port. **TIGHTEN ALL THE CONNECTIONS SECURELY!**
18. Secure hoses together with the 36" of hose wrap and nylon ties.
19. Start the tractor. Actuate the loader to charge the hydraulic system. Add hydraulic fluid as required using the recommended fluid.



TIGHTEN ALL THE CONNECTIONS SECURELY!

2 SPOOL LOAD SENSING/CLOSED CENTER VALVE
PORTS LABELED

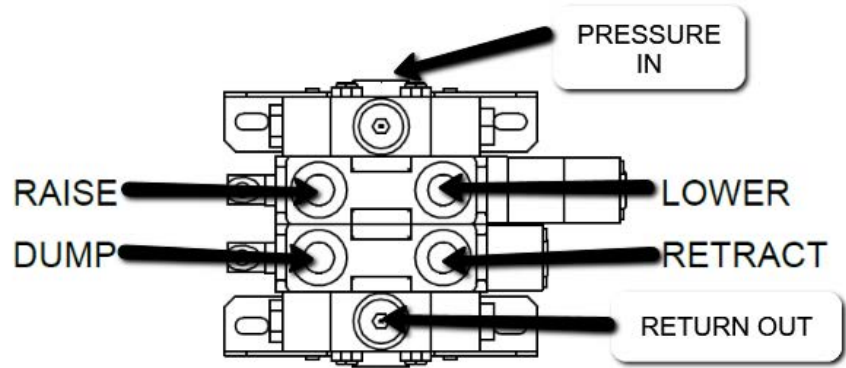

LOAD SENSE IN /
PLUG FOR CLOSED
CENTER

3 SPOOL LOAD SENSING/CLOSED CENTER
VALVE PORTS LABELED

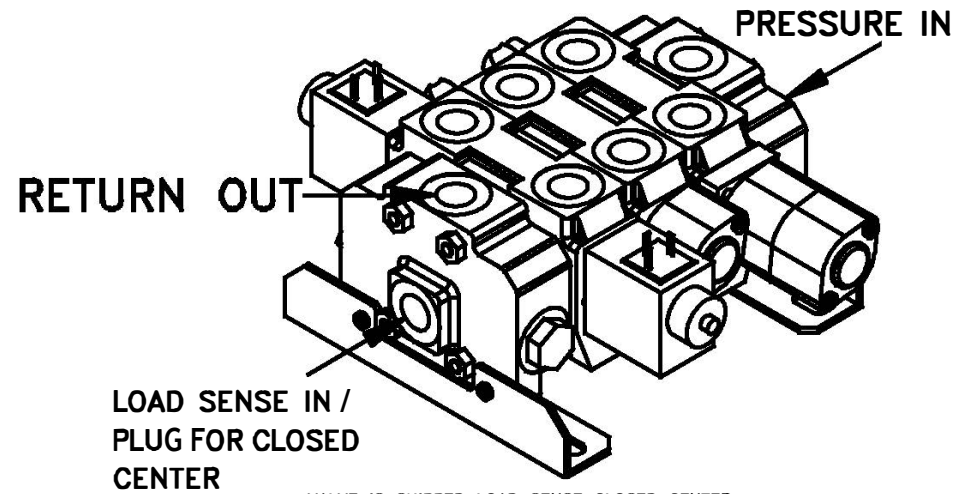
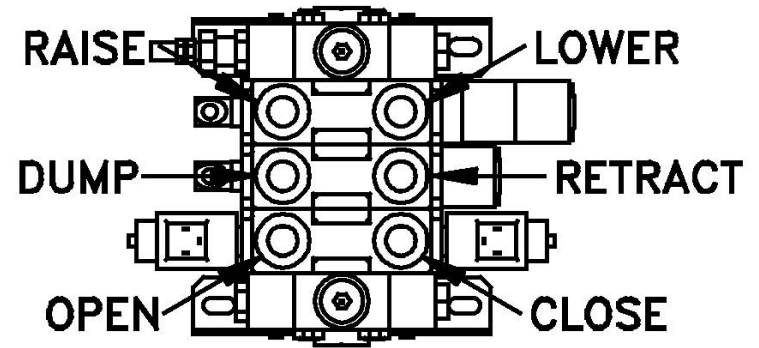

VALVE IS SHIPPED LOAD SENSE CLOSED CENTER.

VIDEOS:

CONNECTING CABLES TO VALVE:

<https://youtu.be/AOKy1CnuU4o>



CONNECTING CABLES TO JOYSTICK:

<https://youtu.be/vbcYCtpPtaw>

